



# HARDTOP CAB

MODEL #11023

FOR JOHN DEERE 4100, 4110

## OPERATION - PARTS LIST - ASSEMBLY



### **WARNING**

THIS HARDTOP CAB WILL NOT PROTECT OPERATOR FROM INJURIES CAUSED BY ROLL-OVER, COLLISION OR OTHER ACCIDENTS

### **IMPORTANT:**

READ THIS OPERATION MANUAL CAREFULLY AND KEEP FOR FUTURE REFERENCE

NEVER TRANSPORT MACHINE WITH VINYL PANELS ATTACHED ON AN OPEN TRAILER OR OPEN TRUCK WHOSE SPEED WILL EXCEED 35 M.P.H

# **LIMITED WARRANTY TRACTOR AND SNOW REMOVAL EQUIPMENT CABS**

## **COVERED BY WARRANTY**

ORIGINAL TRACTOR CAB CO., INC., (the "Company") warrants to the owner that each new product listed below is merchandise free of defects in workmanship and material.

During the warranty period, the dealer from whom the product was bought, or the Company, will provide, free of charge, parts and the shipping costs of parts necessary to correct any defect in workmanship and material.

## **WARRANTY PERIOD**

The company products listed below are warranted for the stated period from the date of the original purchase:

1. Cabs for tractors and snow removal equipment	1 Year
2. Company manufactured accessories for above cabs	1 Year
3. Sunshades for lawn and garden tractors	1 Year
4. Repair parts	1 Year

## **OWNER'S RESPONSIBILITIES**

The owner of a new Company manufactured product must do the following to qualify for warranty service :

1. Retain the original invoice or other proof of purchase to avoid unnecessary difficulties in determining eligibility for warranty work.
2. Notify the dealer from whom the product was bought, or the company, as soon as possible after discovery of a possible defect, and provide proof of original purchase. To notify the company write to: Original Tractor Cab Co., Inc., P.O. Box 97, Arlington, IN 46104.
3. The owner may, upon notification by the Company, be required to return the defective part, or parts, to the Company for inspection and warranty service.

## **NOT COVERED BY WARRANTY**

The following are not covered by this warranty:

1. Transportation charges to and from servicing dealer or the Company;
2. New products which have been subject to misuse, negligence or accident, or have been altered or repaired in a manner not authorized by the company;
3. All implied warranties, except to the extent prohibited by any applicable law, shall have no greater duration than the warranty period for the applicable product, some states do not allow limitation on how long an implied warranty lasts, so the above limitation may not apply to you.

The Company's' liability arising out of warranties representation, instructions, or defects from any abuse, shall be limited exclusively to repair or replacing parts under the condition in the warranty, and in no event will Company be liable for incidental or consequential damages. Some states do not allow the exclusion or limitation of incidental or consequential damages, so the above limitation or exclusion may not apply to you. This warranty gives you specific legal rights, and you may also have rights which vary from state to state.



# WARNING

This cab is designed to provide foul weather protection only. It does not provide protection from noise, exhaust fumes, chemicals or injury from collision, rollover or other accidents.

1. Do not operate machine in confined areas without proper ventilation
2. Thoroughly check area of operation before using machine
3. The cab adds height to the machine. Low tree limbs and other overhead structures that did not interfere with the operation of the machine before, may now be obstacles

## MAINTENANCE INSTRUCTIONS

Periodically check all bolts to see that they are tight. If bolts become loose, failure of cab parts may occur.

Door latches and hinges should be lubricated with light machine oil for proper operation.

**DO NOT CLEAN THE CLEAR PLASTIC WINDOWS WHEN THE PLASTIC IS DRY.  
THE CLEAR PLASTIC WILL SCRATCH.**

Avoid contact with plastic windows. Keep plastic windows clean by washing them with clear running water and rubbing with your bare hands, only. The use of a rag, sponge or brush will scratch the plastic. Liquid soap may also be used for window cleaning. During freezing weather, an automotive windshield washer solvent may be used.

Use liquid soap and water to clean colored vinyl portions. Scrubbing with a brush or rag is also permitted on the colored vinyl portions

## STORAGE INSTRUCTIONS

Prior to storage clean the windows and colored vinyl parts with a mild automotive detergent, rinse with clean water and allow to thoroughly dry, Store cab in a clean dry place out of direct sunlight. Avoid folding plastic windows.

## CARTON CONTENTS

PART #	KEY #	QTY	DESCRIPTION
11028	1	1	FOOT, RH
11029	2	1	FOOT, LH
11030	3	1	BRACE, RH FRONT PANEL
11031	4	1	BRACE, LH FRONT PANEL
10926	5	2	POST, FRONT
10010	6	1	CROSS BAR, FRONT
10002	7	1	BRACE, RH TOP FRAME
10003	8	1	BRACE, LH TOP FRAME
11026	9	1	BRACKET, RH REAR POST
11027	10	1	BRACKET, LH REAR POST
10750	11	1	POST, RH REAR
10751	12	1	POST, LH REAR
11032	13	1	POST, RH BOXING
11033	14	1	POST, LH BOXING
10001	15	1	FRAME, TOP
11025	16	1	BRACKET, ROLL BAR
11024	17	2	CLAMP, ROLL BAR 'C'
11039-B	18	1	DOOR, RH
11034	19	1	DOOR BOTTOM, RH
11040-B	20	1	DOOR, LH
11035	21	1	DOOR BOTTOM, LH
11197	22	1	PLASTIC TOP
11038-B	23	1	FRONT PANEL VINYL
10749-B	24	1	WINDSHIELD
11037-B	25	1	REAR CURTAIN
9820		1	DOOR HARDWARE PACKAGE (Parts List in Package)
11036	HWD	1	HARDWARE PACKAGE (Contents Listed Below)
786	HWD	12	BOLT, 1/4" x 5/8"
788	HWD	6	BOLT, 1/4" x 3/4"
5144	HWD	2	BOLT, 1/4" x 2 3/4"
1514	HWD	12	WASHER, 1/4" FLAT
730	HWD	20	NUT, 1/4" LOCK
4902	HWD	2	PROTECTOR, PLASTIC
8440		2	9/16" O.D. x 3/8" SPACER
9846		2	Bolt 1/4"-20 X 4"
9833		2	3/4" U Clamp

### READ THIS MANUAL COMPLETELY BEFORE BEGINNING INSTALLATION.

- The right side of the machine is determined from the operators seated position.
- The words "bolt" will refer to a 1/4"x5/8" bolt and "nut" will refer to a 1/4" locknut.
- Do not tighten bolts unless told to do so.

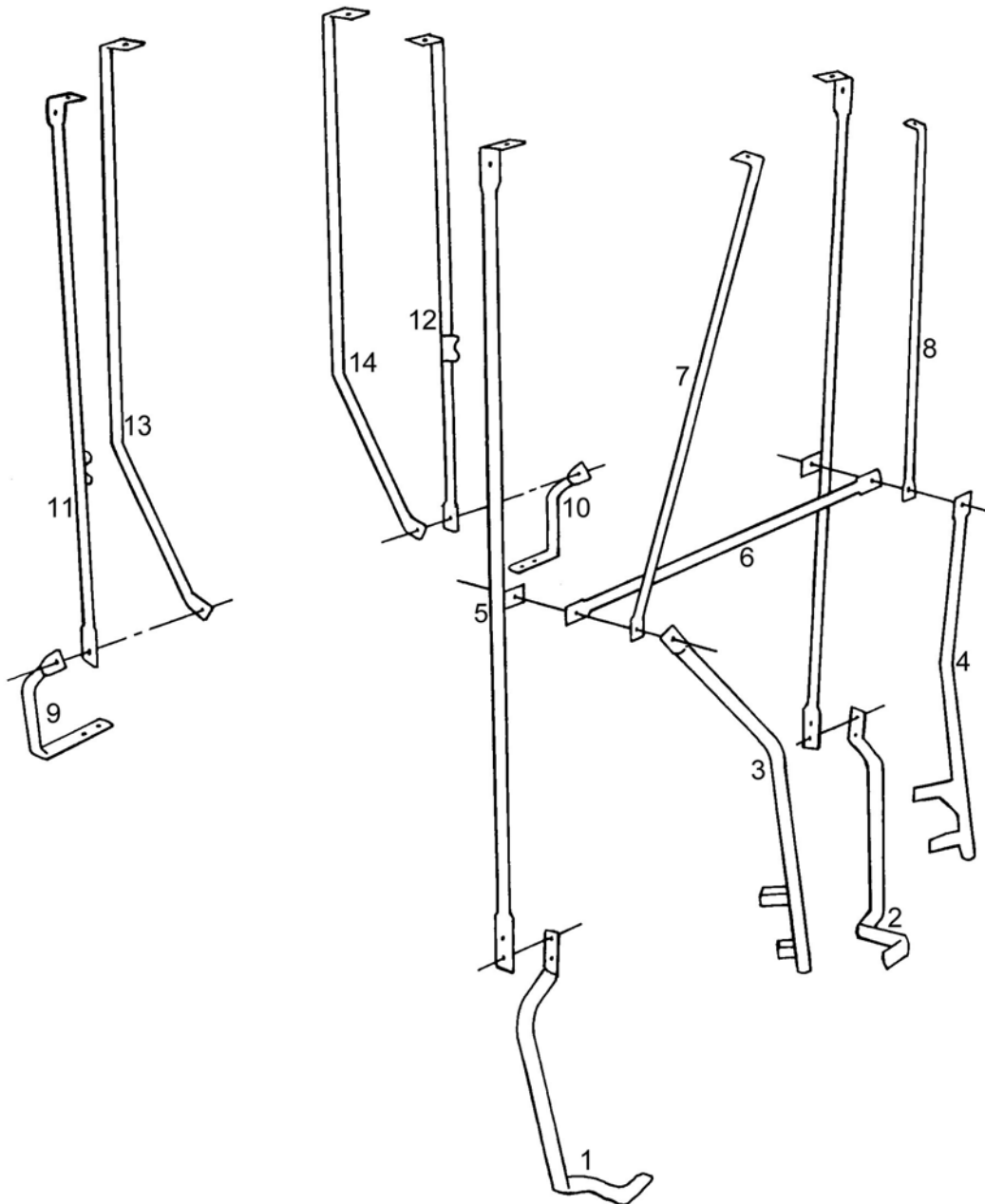
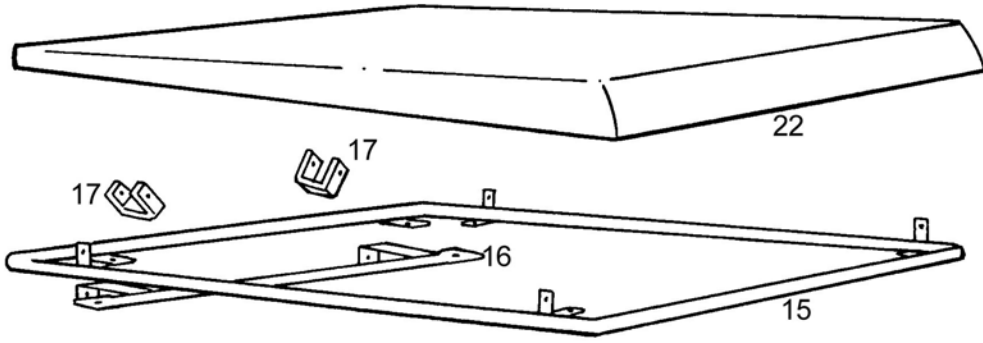

Figure 1

## Supplemental Instructions for 11023 cab for JD 4100, 4110

For tractors with the folding roll bar

**Additional Parts:** Part #9846 Quantity 2 - 1/4" x 4" Bolts,  
8440 2 - 9/16" x 3/8" Spacers,  
9833 2 - 3/4" U Clamps

At step 6 C and step 7 A & B of the cab manual perform these steps instead.

1. Discard Roll Bar Bracket (16) as it is not used for folding roll bar applications.
2. Place the roll bar clamps open end to the inside on the roll bar.
3. Place the 3/4" U Clamps open end down on the rear of the Top Frame (15).
4. Insert the 1/4" x 4" bolt rearwards through the U clamp, add the 9/16" x 3/8" spacer, insert the bolt through the roll bar clamp and add a nut. Do not tighten until steps 10 and 11 are complete.

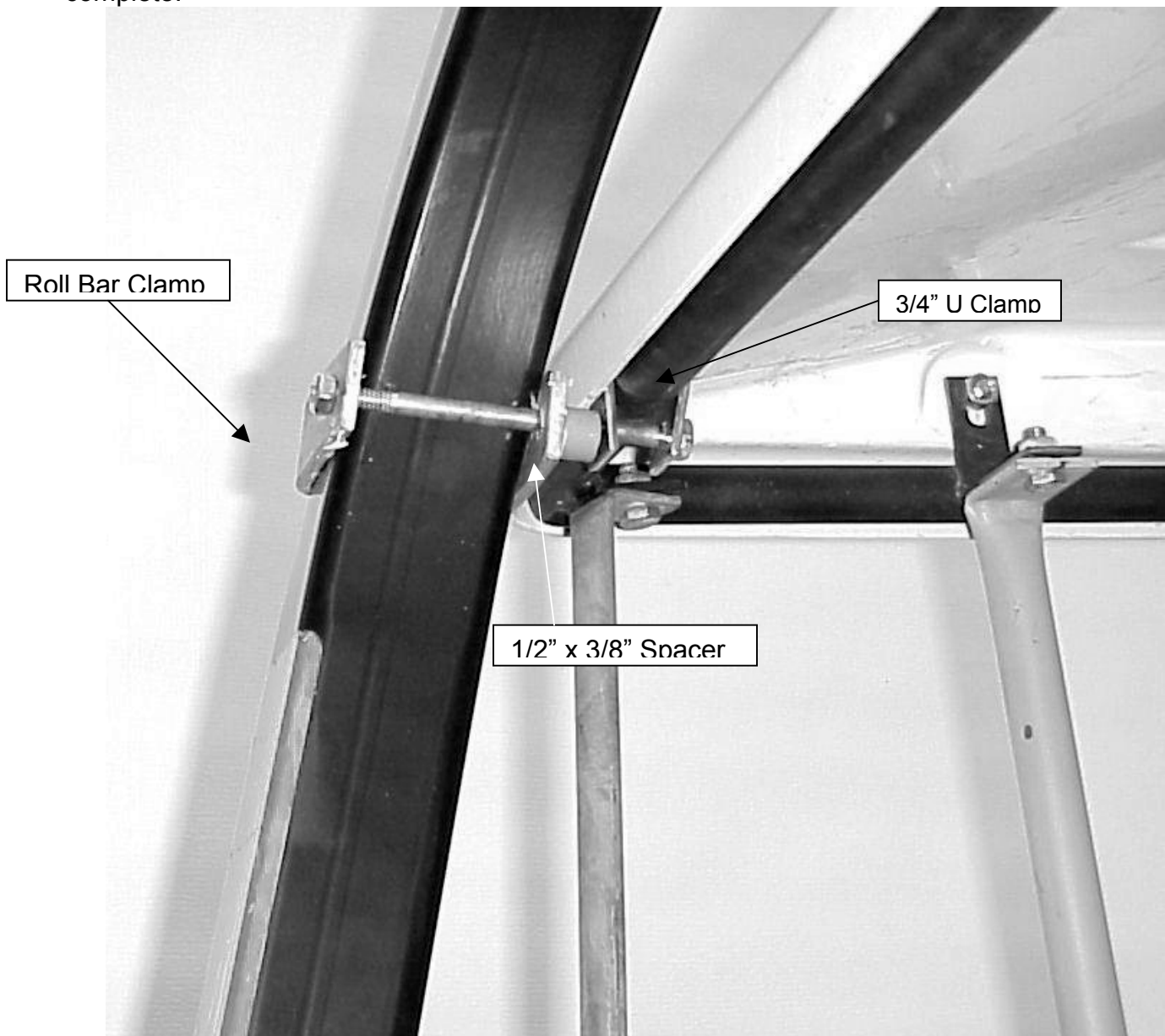

**STEP 1;SEE FIGURES 2 & 3:**

INSTALL:

RH & LH FOOT [1 & 2]

- A. On the underside of the footrest, locate the two bolts that hold the upturned section and the flat section of the footrest together.
- B. Loosen the inner most bolt and remove the outer most bolt. Insert the foot's lower 'L' bracket between the footrest sections.
- C. Reinsert the bolt that held the two footrest sections together, along with the lower bracket of the foot. Thus bolting the footrest sections and the foot bracket together.

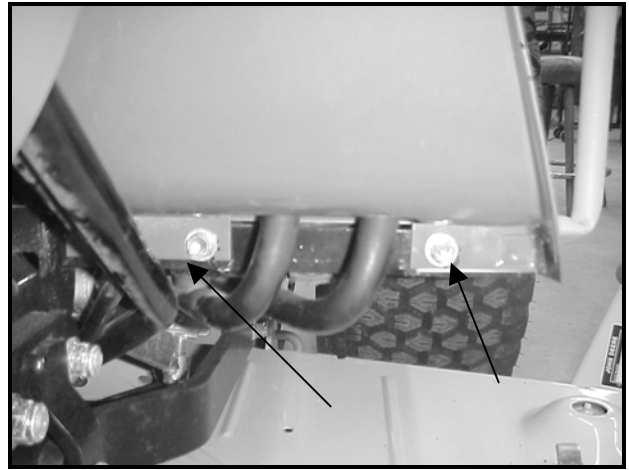

Figure 2

**STEP 2;SEE FIGURE 4:**

INSTALL:

RH & LH FRONT PANEL BRACE [3 & 4]

- A. Remove the two bolts from the side of the lower dashboard panel.
- B. Insert the bolts removed from the dashboard into the tabs of the front panel brace. Place (2) 1/4" flat washers on each bolt to act as spacers.
- C. Bolt the front panel brace into place on the lower dashboard panel where the bolts were previously removed (step 1A).



Figure 3 (Right side)

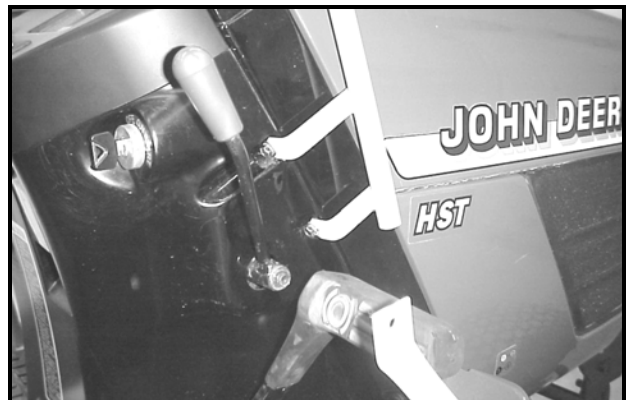

Figure 4

**STEP 3;SEE FIGURE 5:**

INSTALL:

FRONT POST [5]

CROSS BAR [6]

RH & LH TOP FRAME BRACES [7 & 8]

- A. Bolt the straight flattened end (lower hole) of the front post to the flattened end of the foot. Tighten the nut enough to hold the post upright.
- B. Insert a 1/4" x 3/4" bolt into the tabs (mid-point) of the front posts. Onto these bolts install the cross bar, followed by the top frame braces and securing them to the previously installed front panel braces with a 1/4" locknut.



Figure 5

**STEP 4;SEE FIGURE 6:**

INSTALL:  
RH & LH REAR POST BRACKETS [9 & 10]

- A. Remove the two forward bolts from the roll bar mounting plate. Use these bolts to attach the rear post brackets to the tractor.

**NOTE:** Re-tighten roll bar mounting bolts to proper torque. (Reference machine manual)

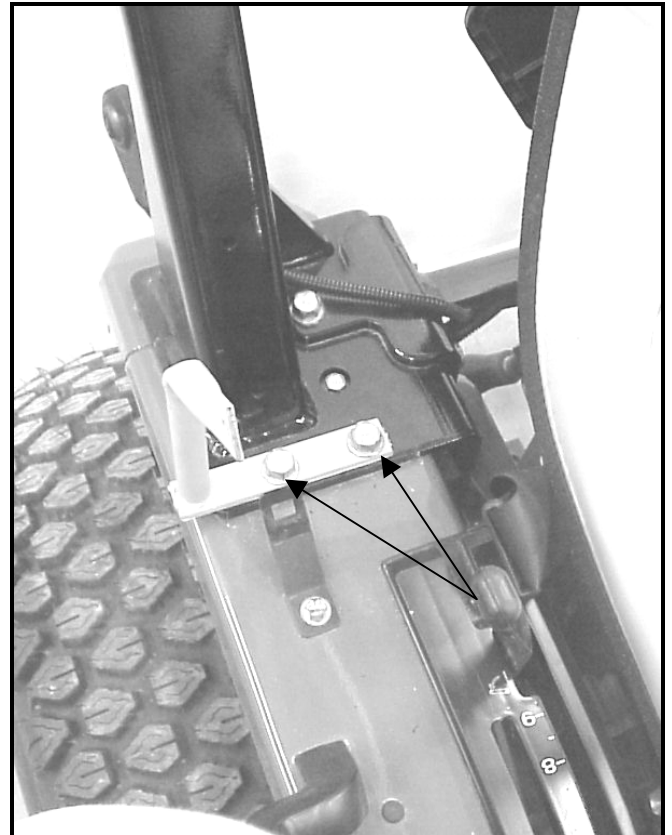

Figure 6

**STEP 5;SEE FIGURE 7:**

INSTALL:  
RH & LH REAR POSTS [11 & 12]  
RH & LH BOXING POSTS [13 & 14]

- A. Insert a 1/4" x 3/4" bolt into the slightly bent and flattened end of the boxing post and the rear post. Insert bolt with the parts into (inside to outside) the flattened end of the rear bracket post. Secure with a lock nut.

**NOTE:** The 'V' shaped bracket (latch plate) on the rear post should be on the front side of the post and the 'V' should be open to the outside of the cab. (See Figure. 15)



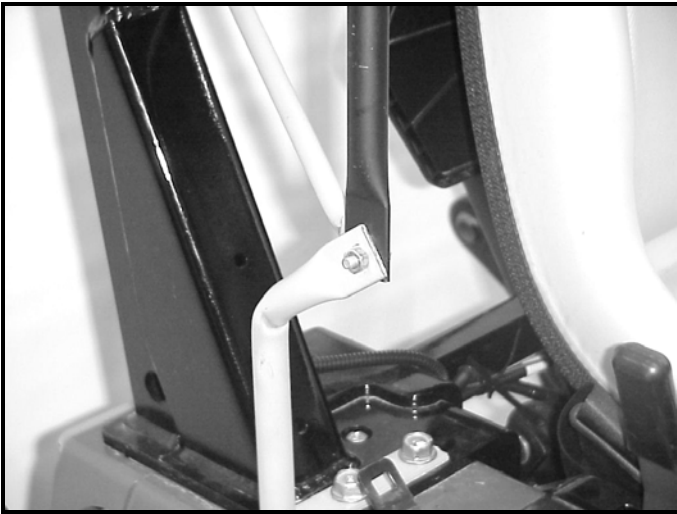

Figure 7

**STEP 6; SEE FIGURE 8:**

INSTALL:

TOP FRAME [15]

ROLL BAR BRACKET [16]

- A. Place the top frame onto the ends of the posts and braces. (Small tabs in the corners are at the rear where the boxing post will attach)
- B. Secure only the top frame braces and the front and rear posts to the frame with a bolt (upward) and nut. Securely tighten bolts.
- C. Place the flattened tubular ends of the roll bar bracket (Long 'L' shaped tabs are on the outside of the frame and pointing down) between the end tabs of the boxing posts and the corner tabs of the top frame. Secure the boxing posts, roll bar bracket and the top frame with 1/4" x 3/4" bolts (inserted upwardly) and 1/4" lock nuts. Securely tighten these bolts.



Figure 8

**STEP 7;SEE FIGURE 9:**

INSTALL:

ROLL BAR CLAMPS [17]

- A. Place a roll bar 'C' clamp over the roll bar from the inside of the roll bar to the outside. Move the 'C' clamp around on the roll bar until the hole in the 'L' tab of the roll bar bracket can be aligned with the hole in the clamp.
- B. From the backside of the clamp insert a 1/4" x 2 3/4" bolt through the clamp's holes and the hole of the 'L' tab of the roll bar bracket. Secure with a 1/4" lock nut.

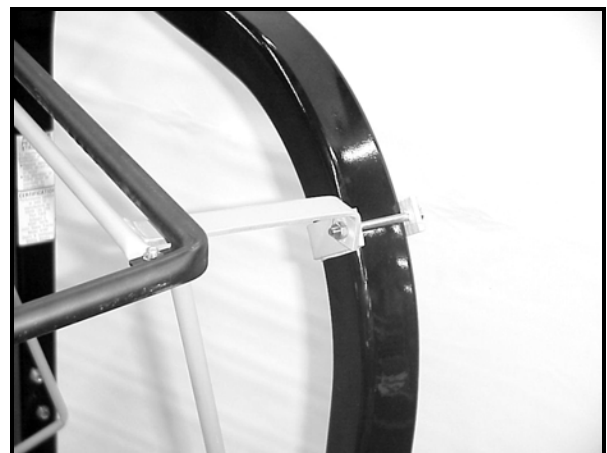

Figure 9

**STEP 8;SEE FIGURES 10 & 11:**

INSTALL:  
FRONT PANEL VINYL [23]

- A. Drape the front panel vinyl over the hood of the machine. Bring the Velcro strip on the outside top edge of the panel to the top edge of the cross bar.
- B. Fasten the snaps around the front posts.

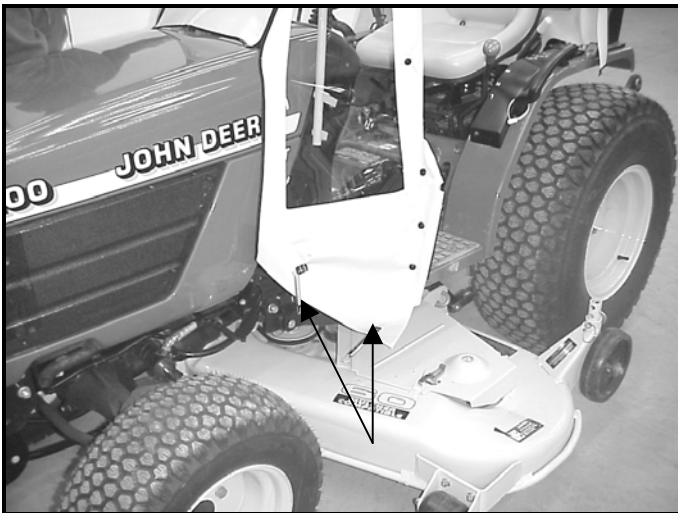

Figure 10



Figure 11

**STEP 9;SEE FIGURES 10, 12 & 13:**

INSTALL:  
WINDSHIELD [24]

- A. Place the sewn in rod at the top edge of the windshield just over the front of the top frame.
- B. Fasten the snap flaps around the top frame and the front posts.
- C. Press the Velcro strip of the windshield onto the Velcro strip of the front panel vinyl. Fasten the ties to the cross bar and attach the spring hooks to the underside of the footrest. **Do not** fasten hooks to any moving parts or control surfaces.



Figure 12



Figure 13

**STEP 10;SEE FIGURES 14 & 15:**  
**INSTALL:**  
**REAR CURTAIN [25]**

- A. Drape the rear curtain between the roll bar and the cab frame. Place the sewn in rod of the top edge of the rear curtain slightly over the rear edge of the top frame.
- B. Fasten the snaps over the top frame and around the rear posts. Fasten the ties around the boxing posts.



Figure 15

**STEP 11;SEE FIGURE 16:**  
**INSTALL:**  
**PLASTIC TOP [22]**

- A. Place the plastic top onto the top frame and bolt into place as shown in the inset of Figure 16.



Figure 14

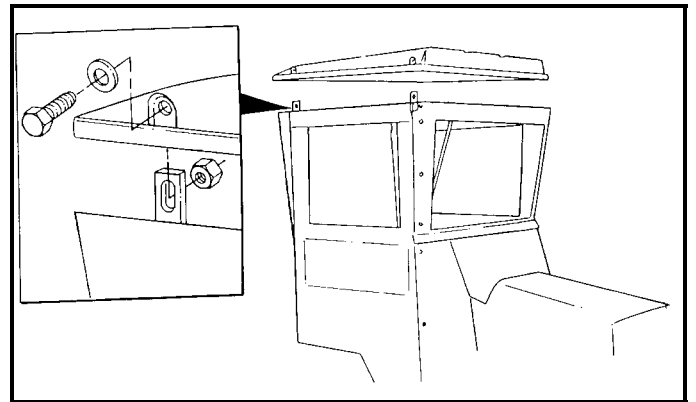

Figure 16

## **STEP 12:**

INSTALL:

HINGES

RH & LH DOORS [18 & 20]

RH & LH DOOR BOTTOMS [19 & 21]

- A. Prepare the doors as per the instructions in the door hardware package.
- B. Bolt two door hinges securely to the top and bottom open holes in the front posts.
- C. Slip the door's upper pivot pin up into the top hinge barrel attached to the front post as far as it will go.

- D. Align the door's lower pivot pin with the bottom door hinge barrel attached to the front post. Lower the pin down into the hinge barrel.

For proper door alignment it may be necessary to loosen some of the frame's bolts, align the doors and retighten the bolts.

The E-Z on and off door system allows the doors to be easily removed by reversing the procedure in steps 12C & 12D.

### **IMPORTANT**

Tighten all bolts prior to using the machine. Check all bolts again after a few hours running time.

## **For Replacement Parts and Accessories Contact:**

**Original Tractor Cab Co., Inc.**

**P.O. Box 97 6849 W. Front St.**

**Arlington, IN 46104**

**Phone 765-663-2214**

**Fax 765-663-2101**

**Email [Sales@originalcab.com](mailto:Sales@originalcab.com)**

**Visit us on the web to see our other products.**

**[www.originalcab.com](http://www.originalcab.com)**

**Cabs for Lawn Tractors, Garden Tractors, Compact Tractors, Snow Blowers, Utility Vehicles**

**Sunshades for Tractors, Mowers, & Utility Vehicles**

**Storage Covers for Lawn and Garden equipment.**