

**66" PRO-POLY  
SERIES PLOW  
BLADE**

**Installation Manual**

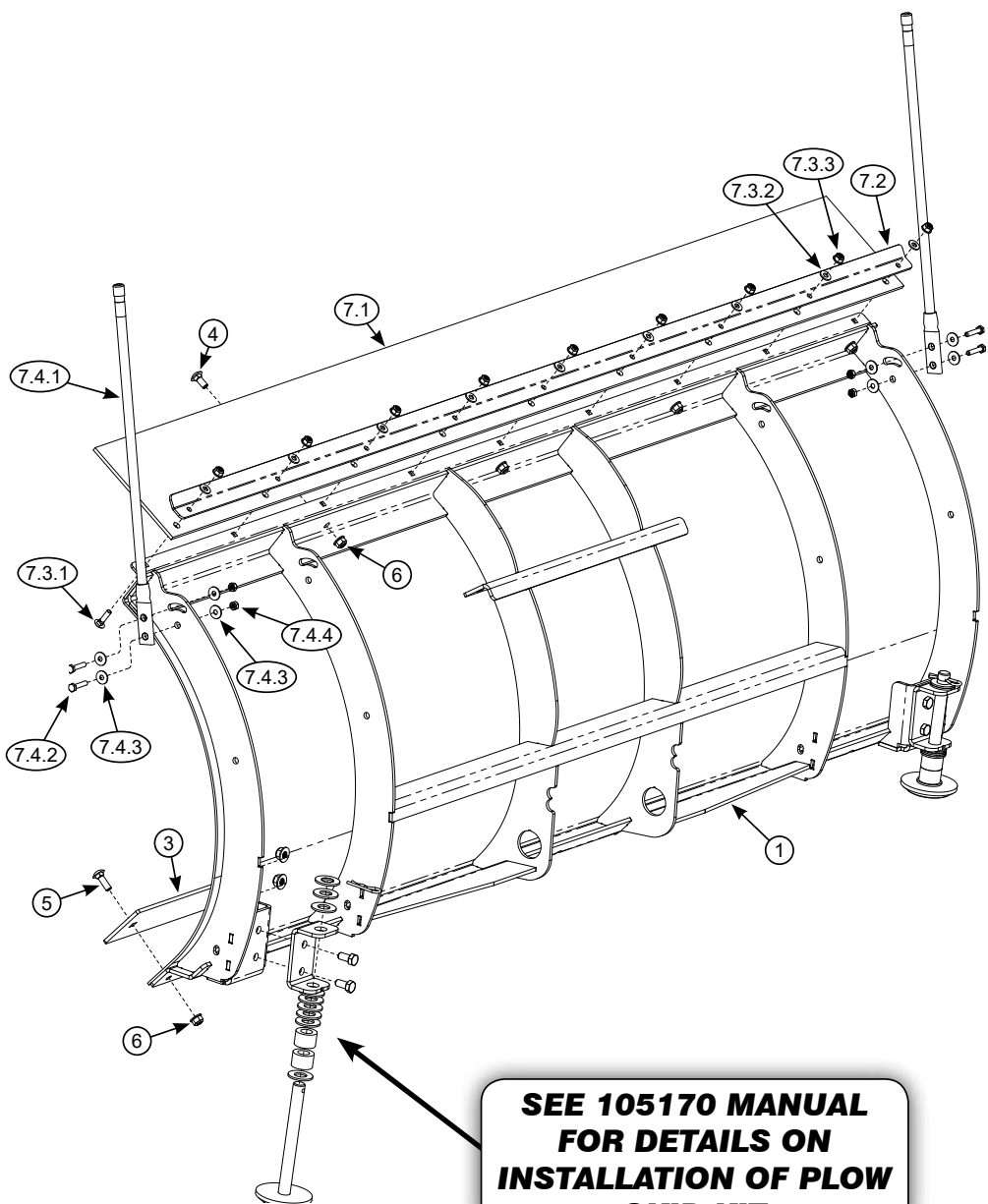



**SEE 105170 MANUAL  
FOR DETAILS ON  
INSTALLATION OF PLOW  
SKID KIT**

# 105866

## PARTS LIST

ITEM	PART#	DESCRIPTION	QTY
1	105867	KFI 66" STRAIGHT BLADE	1
2	105170	SKID KIT	1
3	105274	KFI 66" WEAR BAR	1
4	P890033	5/16-18 X .75 CARRIAGE BOLT GR5	5
5	P890003	5/16-18 X 1.00 CARRIAGE BOLT GR8	9
6	P890014	5/16-18 HEX NUT FLANGE NYLOCK	14
7	106466	66" PLOW FLAP KIT	1
7.1	105279	66" RUBBER FLAP	1
7.2	105361	66" EDGE TRIM	1
7.3	HK-102	HARDWARE KIT	1
7.3.1	CB-5Z-025-20-100	1/4"-20 X 1" CARRIAGE BOLT	9
7.3.2	FW-SAE-Z-025	1/4" FLAT WASHER SAE	9
7.3.3	HNN-5Z-025-20	1/4"-20 HEX NYLOCK NUT	9
7.4	105810	PLOW MARKER KIT	1
7.4.1	P800450	PLOW MARKER STRAIGHT	2
7.4.2	HB-88Z-M6-100-030	M6 X 1.00 X 30MM HEX SCREW	4
7.4.3	FW-Z-M6 X 18	M6 FLAT WASHER	8
7.4.4	HNN-Z-M6-100	M6 X 1.00 HEX NUT, NYLOCK	4

**NOTE:**

**There are 2 possible positions when installing the edge trim (7.2). See Figures 1&2.**

**The wear bar (3) comes installed onto the blade. The Wear Bar is reversible, meaning it can be flipped around after seasonable wear.**

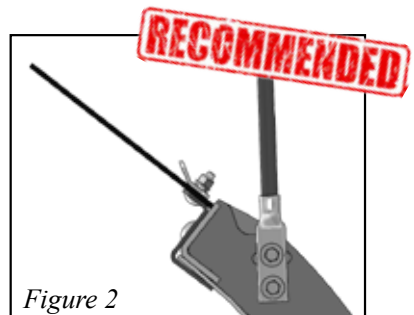
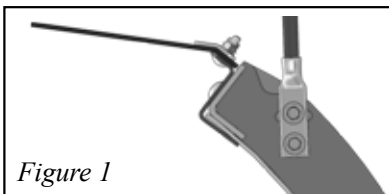



## 2 Year Limited Warranty

Kappers Fabricating, Inc. (KFI) warrants to the original purchaser that the product is free from defects in materials and workmanship for a period of two (2) years from the original date of purchase. We will repair or replace, at our discretion, parts found to be defective due to materials or workmanship. This warranty is subject to the following limitations and exclusions:

**Commercial Use:** The warranty period for any product used for commercial or rental is limited to ninety (90) days from the date of original purchase.

**Limitations:** This warranty applies only to products which have been properly assembled, adjusted, and operated in accordance with the instructions contained within this manual. This warranty does not apply to any product of Kappers Fabricating, Inc. that has been subject to alteration, misuse, abuse, improper assembly or installation, or shipping damage.

**Exclusions:** Excluded from this warranty are normal wear, normal adjustments, and normal maintenance.

**THIS WARRANTY DOES NOT APPLY TO ANY INCIDENTAL OR CONSEQUENTIAL DAMAGES AND ANY IMPLIED WARRANTIES ARE LIMITED TO THE SAME TIME PERIODS STATED HEREIN FOR ALL EXPRESSED WARRANTIES.**

**THE WARRANTY SET FORTH ABOVE IS THE ONLY WARRANTY. THERE ARE NO OTHER WARRANTIES, EXPRESS OR IMPLIED, INCLUDING BUT NOT LIMITED TO IMPLIED WARRANTIES OF MERCHANTABILITY OR FITNESS FOR A PARTICULAR PURPOSE.**

Some states do not allow the exclusion of implied warranties or the exclusion or limitation of liability for incidental or consequential damages, or limitations on how long an implied warranty lasts, so the above limitation or exclusion may not apply to you. This warranty gives you specific legal rights. You may also have other rights that vary from state to state.

In the event you have a claim under this warranty, contact KFI's Technical Service and KFI will troubleshoot any issue via phone or e-mail. If the problem is not corrected by this method, KFI will, at its option, authorize evaluation, repair or replacement of the defective part or component at a KFI Service Center. KFI will provide you with a case number for warranty service. Please keep it for future reference. Repairs or replacements without prior authorization, or at an unauthorized repair facility, will not be covered by this warranty.

All transportation charges, damage, or loss incurred during transportation of parts submitted for replacement or repair under this warranty shall be borne by the purchaser. Should you have any questions concerning this warranty, please contact us toll-free at 1-877-346-2050. The model number, serial number (If applicable), date of purchase, and the name of the authorized KFI dealer from whom you purchased the product will be needed before any warranty claim can be processed.

For warranty inquiries outside the U.S.A. and Canada, contact your local dealer/distributor.

For countries not covered by a local dealer/distributor, please contact us at [www.kfiproducts.com](http://www.kfiproducts.com).

## Product Registration

---

Please register your product with Kappers Fabricating, Inc. (KFI) within fifteen (15) days of purchase to assist us in handling any warranty issues that may arise by filling out this Registration card and submitting it with a copy of your sales receipt from one of KFI's official resellers. Failure to complete and return this Registration card does not diminish your warranty rights.

Please refer to the above section for complete terms of this warranty.

**WARRANTY IS NON-TRANSFERABLE**

Please Print Clearly

Model # \_\_\_\_\_

Name \_\_\_\_\_

Street Address \_\_\_\_\_

City \_\_\_\_\_ State \_\_\_\_\_ Zip Code \_\_\_\_\_

Phone \_\_\_\_\_ Fax \_\_\_\_\_ Email \_\_\_\_\_

Date of Purchase \_\_\_\_\_ Authorized KFI Dealer Name \_\_\_\_\_

Fill out and send this section to:  
KFI Products

Warranty Registration Department  
721 Sata Drive, PO Box 32  
Spring Valley, MN 55975, U.S.A.







Kappers Fabricating, Inc.

721 Sata Dr.  
Spring Valley, MN 55975

1-877-346-2050